

DRAFT INTERNATIONAL STANDARD

ISO/DIS 13031

ISO/TC 127/SC 2

Secretariat: ANSI

Voting begins on:
2015-07-20

Voting terminates on:
2015-10-20

Earth-moving machinery — Quick couplers — Safety

Engins de terrassement — Attache rapide — Sécurité

ICS: 53.100

THIS DOCUMENT IS A DRAFT CIRCULATED FOR COMMENT AND APPROVAL. IT IS THEREFORE SUBJECT TO CHANGE AND MAY NOT BE REFERRED TO AS AN INTERNATIONAL STANDARD UNTIL PUBLISHED AS SUCH.

IN ADDITION TO THEIR EVALUATION AS BEING ACCEPTABLE FOR INDUSTRIAL, TECHNOLOGICAL, COMMERCIAL AND USER PURPOSES, DRAFT INTERNATIONAL STANDARDS MAY ON OCCASION HAVE TO BE CONSIDERED IN THE LIGHT OF THEIR POTENTIAL TO BECOME STANDARDS TO WHICH REFERENCE MAY BE MADE IN NATIONAL REGULATIONS.

RECIPIENTS OF THIS DRAFT ARE INVITED TO SUBMIT, WITH THEIR COMMENTS, NOTIFICATION OF ANY RELEVANT PATENT RIGHTS OF WHICH THEY ARE AWARE AND TO PROVIDE SUPPORTING DOCUMENTATION.



Reference number
ISO/DIS 13031:2015(E)

© ISO 2015



COPYRIGHT PROTECTED DOCUMENT

© ISO 2015, Published in Switzerland

All rights reserved. Unless otherwise specified, no part of this publication may be reproduced or utilized otherwise in any form or by any means, electronic or mechanical, including photocopying, or posting on the internet or an intranet, without prior written permission. Permission can be requested from either ISO at the address below or ISO's member body in the country of the requester.

ISO copyright office
Ch. de Blandonnet 8 • CP 401
CH-1214 Vernier, Geneva, Switzerland
Tel. +41 22 749 01 11
Fax +41 22 749 09 47
copyright@iso.org
www.iso.org

Contents

Page

Foreword	iv
Introduction	v
1 Scope	1
2 Normative references	1
3 Terms and definitions	1
4 Safety requirements and/or protective measures	5
4.1 Quick coupler	5
4.1.1 General.....	5
4.1.2 Engagement system	6
4.1.3 Locking system.....	6
4.2 Object handling.....	7
4.3 Controls.....	7
4.3.1 General requirements.....	7
4.3.2 Separate control	7
4.3.3 Integrated control(s).....	8
4.4 Electrical circuits.....	10
4.4.1 Over-current protective devices.....	10
4.5 Pressurized systems.....	10
5 Information for use	10
5.1 Safety labels.....	10
5.2 Instructions and information for use	10
5.2.1 Operator's manual.....	10
5.2.2 Installation manual.....	11
5.3 Quick coupler marking.....	11
Bibliography	12

Foreword

ISO (the International Organization for Standardization) is a worldwide federation of national standards bodies (ISO member bodies). The work of preparing International Standards is normally carried out through ISO technical committees. Each member body interested in a subject for which a technical committee has been established has the right to be represented on that committee. International organizations, governmental and non-governmental, in liaison with ISO, also take part in the work. ISO collaborates closely with the International Electrotechnical Commission (IEC) on all matters of electrotechnical standardization.

The procedures used to develop this document and those intended for its further maintenance are described in the ISO/IEC Directives, Part 1. In particular the different approval criteria needed for the different types of ISO documents should be noted. This document was drafted in accordance with the editorial rules of the ISO/IEC Directives, Part 2. www.iso.org/directives

Attention is drawn to the possibility that some of the elements of this document may be the subject of patent rights. ISO shall not be held responsible for identifying any or all such patent rights. Details of any patent rights identified during the development of the document will be in the Introduction and/or on the ISO list of patent declarations received. www.iso.org/patents

Any trade name used in this document is information given for the convenience of users and does not constitute an endorsement.

For an explanation on the meaning of ISO specific terms and expressions related to conformity assessment, as well as information about ISO's adherence to the WTO principles in the Technical Barriers to Trade (TBT), see the following URL: [Foreword - Supplementary information](#)

The committee responsible for this document is ISO/TC 127, *Earth-moving machinery*, Subcommittee SC 2, *Safety, ergonomics and general requirements*.

Introduction

This standard specifies design criteria for quick couplers related to assisting the operator in ensuring that an attachment is located in the right position on the quick coupler and that the engagement system is fully activated. While preparing the standard it was considered to what extent the state of the art allowed the further reduction of risks related to engagement procedures not being fully completed. In particular, it was considered carefully whether the use of sensors and associated control systems could be normatively required in order to ensure that those procedures were correctly completed. It was determined that the current state of the art did not allow such a mandatory requirement to be made. However, due to the continuing development of technology this possibility will be reviewed by ISO TC 127 periodically so that a revision to this standard can be initiated at the appropriate time. Nothing in this standard should be taken as discouraging the development of new technologies and new technical measures to reduce or remove risk.

This document is a type C standard as defined in ISO 12100.

The machinery concerned and the extent to which hazards, hazardous situations and events are covered are indicated in the scope of this standard.

When provisions of this type C standard are different from those which are stated in type A or B standards, the provisions of this type C standard take precedence over the provisions of the other standards, for machines that have been designed and built according to the provisions of this type C standard.

Earth-moving machinery — Quick couplers — Safety

1 Scope

This International Standard specifies safety requirements for quick couplers used on earth-moving machinery as defined in ISO 6165.

2 Normative references

The following referenced documents are indispensable for the application of this document. For dated references, only the edition cited applies. For undated references, the latest edition of the referenced document (including any amendments) applies.

ISO 12100, *Safety of machinery — General principles for design — Risk assessment and risk reduction*

ISO 6165, *Earth-moving machinery — Basic types — Identification and terms and definitions*

ISO 6750, *Earth-moving machinery — Operator's manual — Content and format*

ISO 9244, *Earth-moving machinery — Machine safety labels — General principles*

ISO 20474-1:2008, *Earth-moving machinery — Safety — Part 1: General requirements*

3 Terms and definitions

For the purposes of this document, the following terms and definitions apply.

3.1

quick coupler

device mounted on an earth-moving machine to allow the quick interchange of attachments

Note 1 to entry: Quick couplers are also commonly referred to under many different names, including “quick hitch” and “attachment bracket”. For the purposes of this standard only the term “quick coupler” is used.

3.1.1

powered quick coupler

quick coupler where the movement of at least one part of the engagement and locking system is actuated by a power source (e.g. a hydraulic system or an electric motor)

3.1.2

manual quick coupler

quick coupler where the movement of the engagement and locking systems is actuated by human effort at the quick coupler itself

Note 1 to entry: Locking can be automatic as part of the manual process of engagement.

3.1.3

mixed quick coupler

quick coupler where engagement and locking are carried out from the operator's station but disengagement is carried out by human effort at the quick coupler itself

3.2

engagement system

mechanical system of the quick coupler which engages with the attachment and retains the attachment in its working position

**3.2.1
form-locked engagement system**

engagement system which retains the attachment in the normal working position by a system of at least two components that engage each other perpendicular to the working forces such that the working forces do not tend to cause disengagement

EXAMPLE Pin in shear (see [Figure 1](#)).

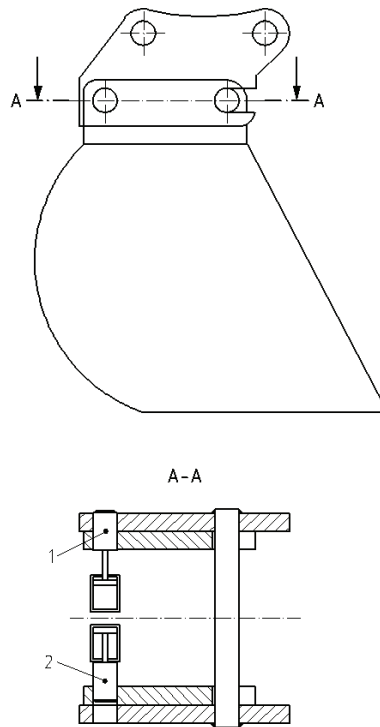

Key

- 1 engagement system in engaged position
- 2 engagement system in disengaged position

Figure 1 — Example of form-locked engagement system

**3.2.2
force-locked engagement system**

engagement system whereby continued engagement is dependent on the continuous application of the engagement force as the working forces act in a direction to cause disengagement

Note 1 to entry: See [Figure 2](#) for an example.

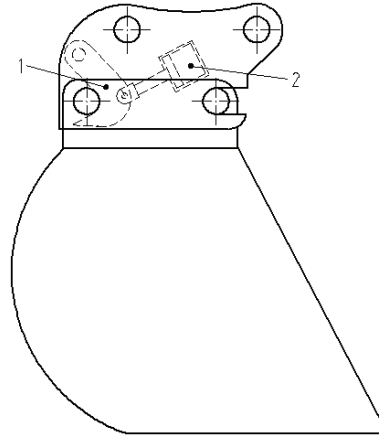
**Key**

- 1 engagement system
- 2 engagement force device

Figure 2 — Example of force-locked engagement system

3.2.3**friction system**

engagement system whereby engagement is dependent on a force generated only by friction

Note 1 to entry: Friction engagement systems are not permitted [see 4.1.2 d)].

Note 2 to entry: See [Figure 3](#) for an example.

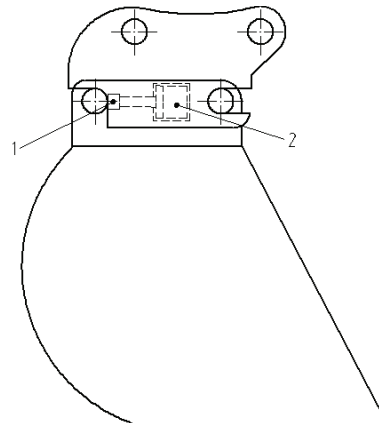
**Key**

- 1 engagement system
- 2 engagement force device

Figure 3 — Example of friction engagement system

3.2.4**wedge-type engagement system**

engagement system of at least two interconnecting parts which engage with one another in a wedge action whereby the combination of the wedge angle and the friction coefficient counteract the tendency of the working forces to cause disengagement

Note 1 to entry: See [Figures 4](#) and [5](#).

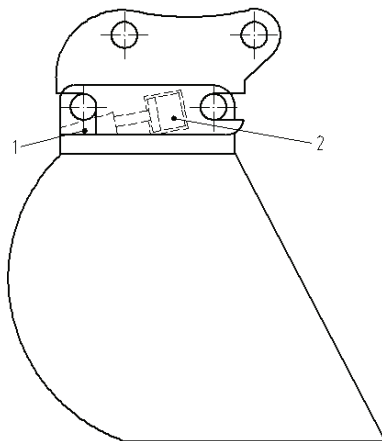

Key

- 1 engagement system (wedge)
- 2 engagement force device

Figure 4 — Example of wedge-type engagement system

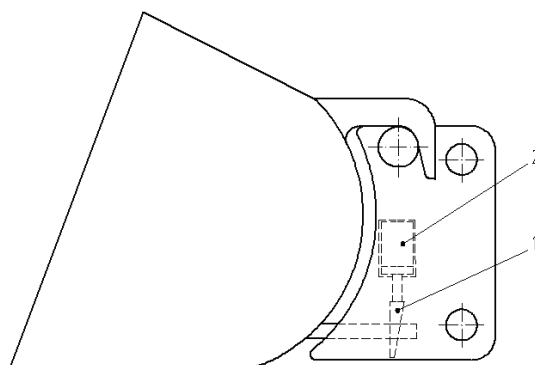

Key

- 1 engagement system (wedge)
- 2 engagement force device

Figure 5 — Example of wedge-type engagement system on a loader

**3.3
Forces**

**3.3.1
working forces**

forces created by the working operations of the machine and attachments that act upon the quick coupler during intended use and reasonably foreseeable misuse

**3.3.2
engagement force**

force that moves the engagement system to the engaged position and, if the design requires, retains it in that position

Note 1 to entry: Engagement force can also be used for retention if the working force or additional forces (e.g. gravity) create a force tending to disengage the attachment (i.e. force-locked engagement systems, wedge-type engagement systems).

3.4 locking system

system that ensures that the attachment is retained in its working position if the engagement force is lost, reduced, or removed

3.5 Controls

3.5.1 separate control

control solely dedicated to the quick coupler which is not integrated into, or mounted on to, any other machine control, and does not have any other function

Note 1 to entry: A switch mounted on a control joystick is not considered to be a separate control.

Note 2 to entry: A separate switch can be integrated into an instrument cluster or control panel.

3.5.2 integrated control

control used to engage and/or disengage the coupler which is integrated into, or mounted onto, any other machine control, or a control which also has another function

EXAMPLE Switch on a joystick control.

3.5.3 initiating control

control that enables a disengagement control to function

3.5.4 disengagement control

control which connects the disengagement actuator to its power supply

Note 1 to entry: In a system with integrated controls the disengagement control is enabled by the initiating control.

3.5.5 hold-to-run

type of control device which initiates and maintains quick coupler functions only as long as the manual control is actuated

[SOURCE: ISO 12100:2010, 3.28.3 (adapted)]

4 Safety requirements and/or protective measures

4.1 Quick coupler

4.1.1 General

Machinery shall comply with the safety requirements and/or protective measures of this clause. In addition, the machine shall be designed according to the principles of ISO 12100 for relevant but not significant hazards which are not dealt with by this document.

The quick coupler shall have an engagement system and a locking system that meet the requirements of [4.1.2](#) and [4.1.3](#) respectively.

NOTE The process of coupling consists of several steps such as picking up, locating, engagement and locking. Depending on the design some of these steps might be combined.

The design of quick couplers shall ensure that the attachment is retained in the working position even when the machine is switched off or being transported. Small displacements between the attachment

and the engagement system are acceptable provided that the movement is not so large as to create a hazard.

4.1.2 Engagement system

The engagement system shall meet the following requirements.

- a) The engagement system shall be able to withstand the working forces applied to the attachment and hold the attachment in the working position.
- b) Typical engagement systems are form-locked system, force-locked system or wedge-type system, or combinations of these styles. Where the engagement system is a combination of these styles then the most appropriate requirement specified in [4.1.2](#) and [4.1.3](#) shall be applied. The engagement system shall not be a friction system.
- c) It shall be possible to verify (e.g. by sensing, visual indication, visual check during testing), from the location where the engagement system is operated (e.g. the operator's station), that the engagement system is fully engaged with the attachment in its working position. If necessary any combination of sensing, visual indication or testing may be used to ensure that the attachment is fully engaged. Testing by machine operation (e.g. by the application of working forces to the attachment) as the sole means of verification is not acceptable.
- d) Wedge-type systems and force-locked systems shall provide a continuous engagement force (e.g. hydraulic pressure, spring force) during the working operation to hold the attachment in the working position.
- e) Manual and mixed quick couplers shall be designed such that disengagement can only be carried out at the quick coupler itself.
- f) For a manual quick coupler, the design shall ensure that the engagement system can only be activated from the location where the locking system is activated.
- g) The engagement system shall not depend solely on gravity.

4.1.3 Locking system

The locking system shall meet the following requirements.

- a) The design of the locking system shall be appropriate to the design of the engagement system (see [Table 1](#)).
- b) It shall prevent disengagement of the attachment if the engagement force is lost, reduced or removed and shall ensure that the attachment is retained in the working position. If the engagement force(s) is lost or reduced, small movements of the attachment are acceptable provided that the movement is not so large as to create a hazard. Movements of the attachment such as swinging or rotation around a mounting point are not considered as small movements.
- c) For powered and mixed quick couplers, the locking system shall be activated automatically as part of the engagement process.
- d) For manual quick couplers the locking system shall be activated manually from the location where the engagement system is operated, or as an automatic action during the engagement process. Any locking device used must be retained on the coupler so that it cannot be removed without the use of tools.
- e) In the event of loss of engagement force the working forces applied to the attachment shall not result in the loss of the locking function.
- f) The locking system, once activated, shall remain locked until the disengagement process is initiated by the operator.

g) The locking system shall not depend solely on gravity.

Table 1 — Locking systems

Engagement system	Example	Locking system
Form-locked	Figure 1	A device (e.g. check valve, spring) or function (e.g. hydraulic pressure) is required to prevent the retraction of the engagement device.
Force-locked	Figure 2	A mechanical device consisting of a form locked or other rigid system is required to prevent retraction of the engagement device. It shall be strong enough to withstand the full working forces and ensure that the attachment is retained in its normal working position.
Friction (not permitted)	Figure 3	—
Wedge-type	Figure 4 and Figure 5	A device (e.g. spring, mechanical lock) is required to prevent disengagement of the wedge in the event of reduction or loss of the engagement force. This may be a separate device or function or may be combined or integrated with the solution of 4.1.2, d).

4.2 Object handling

Object handling shall be in accordance with ISO 20474-1.

NOTE Regional requirements on object handling can apply e.g. EN 474-1.

4.3 Controls

4.3.1 General requirements

Powered quick couplers shall be activated by a separate control meeting the requirements of [4.3.2](#), or by an integrated control system meeting the requirements of [4.3.3](#). Quick coupler controls shall be identified in accordance with ISO 10968.

NOTE For guidance on the validation of safety related control systems, see ISO 13849-1.

Manual switch-over of devices (e.g. hydraulic valve, reconfiguration of hoses) located outside of the operator's station to switch between the quick coupler operation and another machine function are not permitted with powered quick couplers.

Where there is more than one quick coupler installed the controls shall be so designed, arranged or located as to minimize the risk of accidentally operating the wrong coupler.

4.3.2 Separate control

A separate control shall be protected against inadvertent activation (e.g. guarding, location, switch design).

If the control for the disengagement function is not of the hold-to-run type, then the following requirements apply:

- a) an acoustic signal shall be in continuous operation during the period of time the disengagement function is activated;
- b) neither unlocking nor disengagement shall be possible if the electrical signal for the acoustic signal device fails; e.g. by cable failure, disconnection;

- c) the acoustic signal operation shall be activated automatically at every engine start in order to allow verification of the signal by the operator.

4.3.3 Integrated control(s)

If the disengagement of the attachment is not actuated by a separate control, the following requirements shall be met:

- a) disengagement of the attachment shall require the activation of at least two independent controls which shall be arranged so that they cannot be simultaneously operated by one hand;
- b) the initiating control shall be protected against inadvertent activation (e.g. guarding, location, switch design);
- c) if the initiating control for the disengagement function is not of the hold-to-run type, then:

either (a) (option 1 in [Figure 6](#))

- the disengagement control shall not be solely the operation of a joystick or other machine control unless, by design, the attachment cannot be released unless it is positioned such that it is retained in a stable condition after disengagement, ready for placing on the ground;
- the disengagement control shall either be hold to run or shall be reset (i.e. returned automatically to the state prior to initiation of disengagement) when the initiating control is deactivated;
- an acoustic signal shall be in continuous operation while the initiating control is activated;
- neither unlocking nor disengagement shall be possible if the electrical signal for the acoustic signal device fails; e.g. by cable failure, disconnection;
- the acoustic signal operation shall be activated automatically at every engine start in order to allow verification of the signal by the operator.

or (b) (option 2 in [Figure 6](#)):

- simultaneous operation of the initiation and disengagement controls is required to initiate disengagement;
- the disengagement control shall be hold-to-run;
- the initiation of the disengagement function shall be deactivated if the disengagement control is released.

The use of a joystick, or a switch mounted on a joystick, to increase flow or pressure as part of the disengagement process shall be considered as an integrated control.

Where a quick coupler control has an alternative function (e.g. work equipment manipulation and the raising of pump pressure) which is not deactivated while engagement or disengagement is in progress, the alternate function control shall be necessary for the engagement or disengagement of the attachment. e.g. the bucket control on an excavator.

4.4 Electrical circuits

In order to avoid incorrect connections, electric wires and cables used to connect components in electric circuits shall be marked and identified.

NOTE ISO 9247 can be used as guidance.

4.4.1 Over-current protective devices

Electric equipment shall be protected with an over-current device (e.g. fuse) or other device giving the same protection.

NOTE Refer to ISO 20474-1 over-current protective device requirements.

4.5 Pressurized systems

Pressurized systems shall comply with ISO 20474-1:2008, 4.18.

5 Information for use

5.1 Safety labels

Safety labels (if any) shall comply with ISO 9244.

5.2 Instructions and information for use

5.2.1 Operator's manual

An operator's manual complying with ISO 6750 shall be provided. The manual may be integrated into the operating manual for the base machine and shall contain the following, if applicable:

- The design, range and type of attachments intended to be used with the quick coupler.
- Information that the attachment should be within the recommended limits for the carrying machine when a quick coupler is installed.
- Either the models of machine onto which the coupler is intended to be assembled, or a definition of the limits of the machine parameters suitable for the coupler.
- Change to the working range of the machine (e.g. change to load radius, maximum operating capacity, change in machine centre of gravity, reduction in the load capacity chart).
- New risks (if any) of contact between the attachment and the structure of the machine (e.g. the cab).
- Information on daily checks to be carried out before commencement of work.
- The manufacturer's recommended method for safely ensuring that the quick coupler is fully engaged and locked, which should cover all attachments intended to be used with the quick coupler.
- Specification by the manufacturer of a safe method for carrying out the disengagement.
- Advice relating to object handling with the coupler and any factors to be taken into account when using the earth-moving machine rating table (e.g. due to a different load radius, reduction in the lift capacity).
- Advice on procedures to be followed for object handling with the coupler (if allowed), which should include whether the attachment is to be left in place or removed.
- Notice that it is not permitted to transport or lift persons with a quick coupler if the machine is not designed and equipped for this purpose.

- Lifting capacity of the coupler when used with a lifting attachment.
- Advice on how to verify that the engagement system is functioning correctly.

5.2.2 Installation manual

Where relevant (e.g. if the coupler is separately placed on the market), full instructions shall be given for safe assembly and testing of function and performance, including the minimum and maximum hydraulic pressure.

5.3 Quick coupler marking

Each coupler, if separately placed on the market, shall bear the following minimal information, which shall be clearly marked in a location where the risk of damage is minimized:

- manufacturer's name and address;
- type denomination (e.g. part number);
- serial number;
- year of manufacture;
- mass of coupler, expressed in kilograms (kg);
- maximum and minimum quick coupler circuit pressures, expressed in MPa, if relevant.

In addition, the rated capacity of the lifting point (if any) in kg or tonnes (t) which shall be clearly marked adjacent to the lifting point.

NOTE Regional requirements should be taken into account e.g. CE marking.

Bibliography

- [1] ISO 15998, *Earth-moving machinery — Machine-control systems (MCS) using electronic components — Performance criteria and tests for functional safety*
- [2] ISO 13849-1, *Safety of machinery — Safety-related parts of control systems — Part 1: General principles for design*
- [3] ISO 9247, *Earth-moving machinery — Electrical wires and cables — Principles of identification and marking*
- [4] EN 474-1, *Earth-moving machinery – Safety – Part 1: General requirements*

